



# EVERY INSTRUCTION.

**Instruction Manual  
Fuel Consumption Monitor: G Drive  
Part No.: AX1006411**

# INDEX

Section 1 : Introduction	1
Section 2 : Specifications	2
Section 3 : Description	3
Section 4 : Installation & Operation	4
Section 5 : Flow Indicator	6
Section 6 : Trouble Shooting Chart	7
Section 7 : Replacing The Filter Element	8
Section 8 : Replacing The Float Assly	10
Section 9 : Cleaning The Flow Sensor Assly	12
Section 10 : Servicing The Check Valve Assly	15
Section 11 : Replacing The Totaliser Lithium Battery	17
Section 12 : List Of Recommended Spares	19
Section 13 : Frequently Asked Questions (FAQs)	20
Section 14 : Fuel Hour Measurement Calibration	21
Section 15 : Do's & Don'ts For Installation & Use	22

# Section 1.

## Introduction

The Fuel Consumption Monitor is compact fuel flow measuring system suitable for monitoring the net fuel consumption of all makes of engines and gensets after accounting for the return fuel from the engine. The unit is provided with a flow indicator which ensures accuracy and long term reliability.

## Features

- High accuracy guaranteed over a wide flow range of 6 – 500 LPH
- Built in arrangement for deaerating and accounting for the return fuel
- Measures actual net engine fuel consumption for HSD,SKO,HSD+SKO mixture and LDO
- Measures actual engine run hours
- Gravity head not essential for operation. Operates even on negative suction head
- Built in Lithium battery, no external power required
- Compact and light weight construction suitable for portable use



## Section 2.

### Specifications.

#### Flow Sensor:

Type	Positive Displacement
Flow Range	6 – 500 LPH
Accuracy	+/- 0.5% of reading
Service	HSD/SKO/HSD+SKO/LDO/HCR
Ambient Temperature	0 - 50° C
Operating Temperature	0 - 70° C
Display	a) 8 digit LCD Fuel Totaliser 9999999.9 Litre b) 8 Digit LCD Engine Run Time Totaliser 999999.99 Hrs.(Optional)
Filter Element	Built in 149 Micron Reusable
Port Size	a) Inlet – 3/4" BSP (F) b) Outlet – 3/4" BSP (F) c) Injector Return-1/2" BSP (F) + Fuel Pump Return
Power Supply	Built in Lithium battery, 1 years life
Mounting	On fabricated mounting frame

## Section 3.

### Description

The unit consists of a highly accurate positive displacement flow sensor provided with a built in filter element. The liquid displacement inside the flow sensor causes its rotary piston to rotate. The rotation of the piston is sensed by a magnetic sensor and converted to electrical pulses. These pulses are calibrated and displayed by the fuel totaliser. The flowsensor also houses a engine run time totaliser actuated by an engine mounted external Engine ON/OFF Sensor. The engine run time is displayed on the LCD time totaliser.

Apart from the diesel suction port from the storage tank and the diesel outlet port to the engine, the unit is provided with two engine return port. The return fuel from the injector and the fuel pump should be ported to the two return ports as shown. A unique high efficiency vapour separator is provided to deareate return fuel of entrapped air and fuel vapours. The released vapours are vented through a breather. The deareated fuel is circulated back to the engine along with fresh make up fuel.

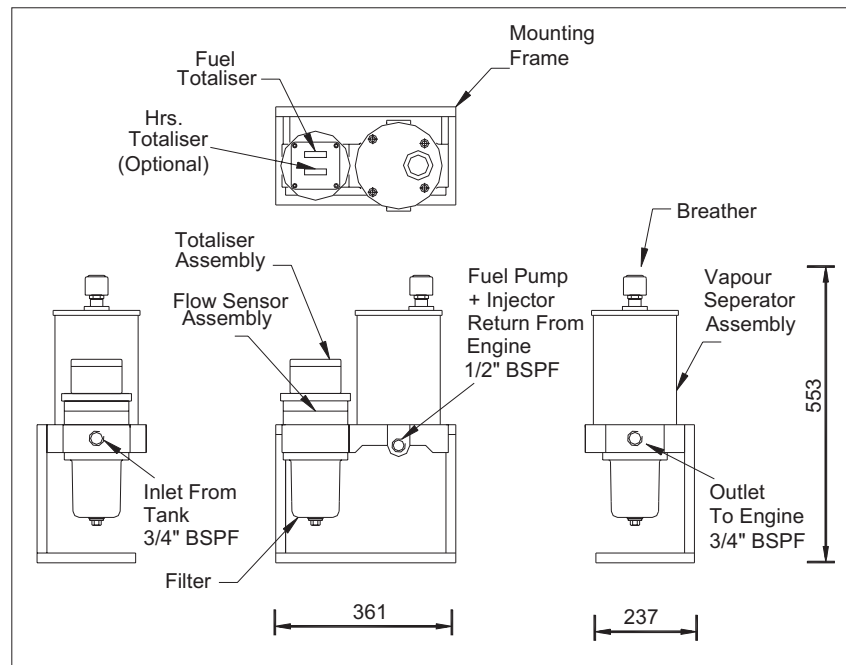

# Section 4.

## Installation & Operation

- With the help of the mounting fasteners provided grout the mounting frame of the unit firmly on the ground besides the genset. **(Mounting on the engine base rail is not recommended.)**
- Ensure that the built in filter element provided on the unit is clean.
- Connect the following hoses as shown
  - a) The fuel inlet hose connected to the Fuel Storage Tank through the isolation valve and Suction Filter should be connected to the Inlet port of the unit. Isolation valve should be kept closed prior to the initial commissioning of the unit.
  - b) Suction fuel hose from the engine is connected to the Outlet port of the unit.
  - c) Injector Return hose to be connected to the Injector Return port of the unit.
  - d) Fuel Pump Return hose should be connected to the Fuel Pump Return Port of the unit.
- **Caution :**
  - 1) **It is very important to ensure that the suction hose connected to the engine fuel pump is completely primed before attempting to start the engine. Failing to do so will result in engine hunting or complete stoppage.**
  - 2) **It is equally important to ensure leak tight joints at the inlet and outlet ports since these are connected on the suction side of the Fuel Pump. Even a minute leak in these connection would cause engine hunting or complete stoppage.**
- Connect the Engine ON/OFF Sensor (Optional) Input to a recommended Engine ON/OFF Sensor mounted on the oil handling manifold preferable on the delivery side of the Lube Filter. This input serves to activate the engine run hour time totaliser. preferable on the delivery side of the Lube Filter.  
Recommended Cummins Safety Control Switch :
- Couple the Connector provided on the Engine ON/OFF Sensor and the Totaliser Assembly.

## Operation

- Open the isolation valve and allow the fuel to enter the Inlet Port of the unit.
- Loosen the engine suction hose connector at port S and bleed fuel to remove the air trapped in the line. Tighten the fittings on ensuring that all the air has been removed.
- Loosen the air bleed screw on the fuel pump of the engine and bleed any entrapped air if present.
- Reset the fuel and time totaliser and start the engine.
- The fuel totaliser will read the fuel consumed by the engine in litres.
- As the engine comes on, the lube oil pressure will build which closes the contacts of the Engine ON/OFF Sensor. The closed contacts activate the Engine run time totaliser to measure the run time in Hrs. On stopping the engine the contacts open, deactivating the time totaliser.

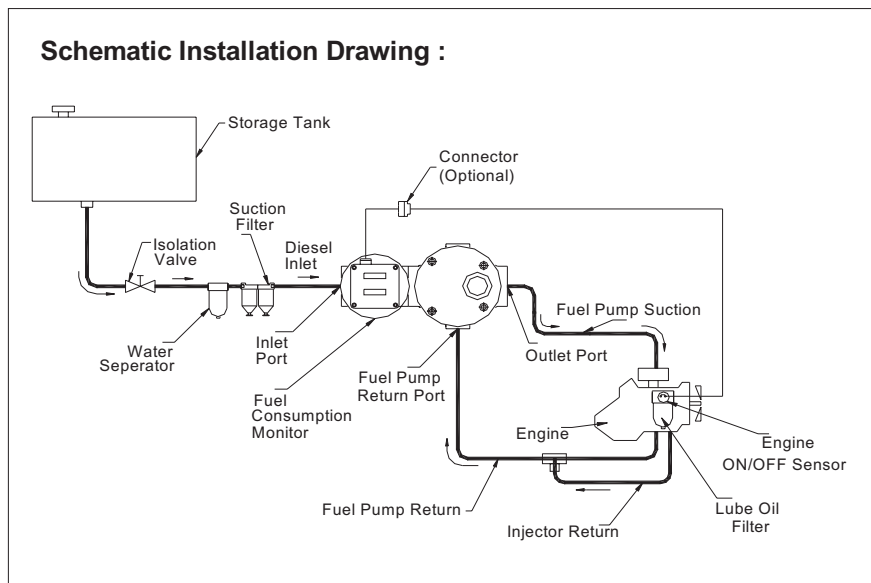

# Section 5.

## Flow Indicator

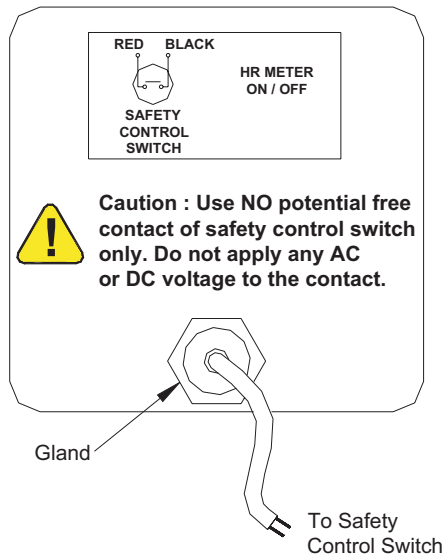
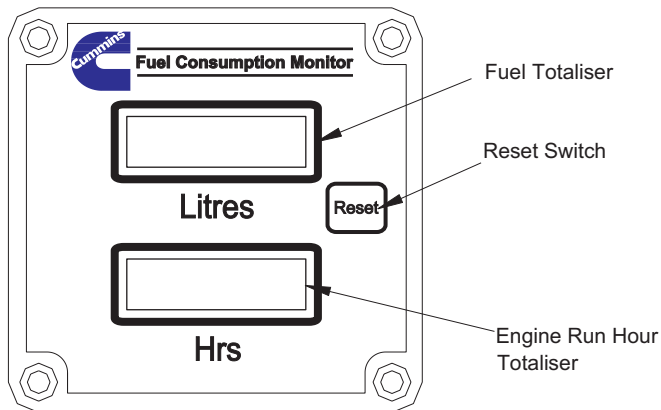

## Section 6.

### Trouble Shooting Chart

Sr. No.	Observation	Defects	Remedial Action
01.	Engine starves, No Fuel supply.	a) Very low or zero fuel level in the Storage Day Tank. b) Chocked Filter Element. c) Suction leak in connection Hoses (For -ve suction head installations only)	<ul style="list-style-type: none"> <li>Replenish Storage Day Tank Level and maintain proper fuel level.</li> <li>Replace Filter Element, <b>Ref. Replacing the Filter Element, Pg. No. 8.</b></li> <li>Click and retighten all hoses.</li> <li>Sticking Non Return Valve Poppet.</li> </ul>
02.	Fuel Leakage from Breather Assembly	a) Defective Air Release Valve in Float Assembly.	<ul style="list-style-type: none"> <li>Replace Float Assembly. <b>Refer Replacing The Float Valve Assembly, Pg No. 10.</b></li> </ul>
03.	Fuel Totaliser and Hour Totaliser display is blank.	a) Run down Lithium Battery.	<ul style="list-style-type: none"> <li>Replace Lithium Battery Assembly <b>Refer Replacing the Totaliser Lithium Battery Pg. No. 16.</b></li> </ul>
04.	Engine Hour Meter does not record engine run time. (Optional Feature)	a) Defective Engine ON/OFF Sensor.	<ul style="list-style-type: none"> <li>Check Sensor contact for proper operation.</li> <li>Replace Safety unit Switch if found defective.</li> </ul>
05.	Fuel Totaliser does not record flow though engine runs satisfactorily.	a) Flow Sensor Piston rotation is not free. b) Incorrect Flow Sensor calibration.	<ul style="list-style-type: none"> <li>Clean Flow Sensor Assembly. <b>Refer Cleaning The Flow Sensor Assembly, Pg.No.12</b></li> <li>Recalibrate The Flow Sensor. <b>Refer CDSS Technical Service Dept.</b></li> </ul>

# Section 7.

## Replacing The Filter Element

### Refer Filter Assembly Schematic

The Flowsensor is provided with a 25 Micron replaceable paper filter element. Depending upon the contamination of the fuel it will be required to periodically change the filter element. The frequency of filter element change will depend on the extent of contamination and may vary from site to site. To replace the filter element proceed as follows. Refer Filter assembly Schematic.

- Isolate the fuel supply to the unit from the storage tank.
- Remove Drain Plug ( 8 ) and drain out the fuel from the Filter Housing from the Flow Sensor Assembly ( 1 )
- Remove 04 Hex Bolt M6 X 20 ( 6 ) to detach the Filter Housing from the Flow Sensor Assembly ( 1 )
- Pull out Filter Element ( 2 ) from the manifold provided on Flow Sensor Assembly
- Fully push in the new Filter Element on the round boss provided
- Examine 'O' Ring Seal ( 3 ) on the face of the Filter Housing. Replace if found damaged
- Placing the face of the Filter Housing on the Flow Sensor assembly manifold, assemble 04 M6 X 20 Hex Head Bolts firmly tighten all four bolts.
- Examine Dowty Washer ( 7 ). Replace if the sealing rubber ring is found damaged
- Assemble the drain plug and the dowty washer and tighten firmly
- The unit is now ready for regular use.

**\*Important : It is recommended to replace the Filter Element once in six months to ensure trouble free performance of the Fuel Consumption Monitor.**

### Filter Assembly Schematic Drawing

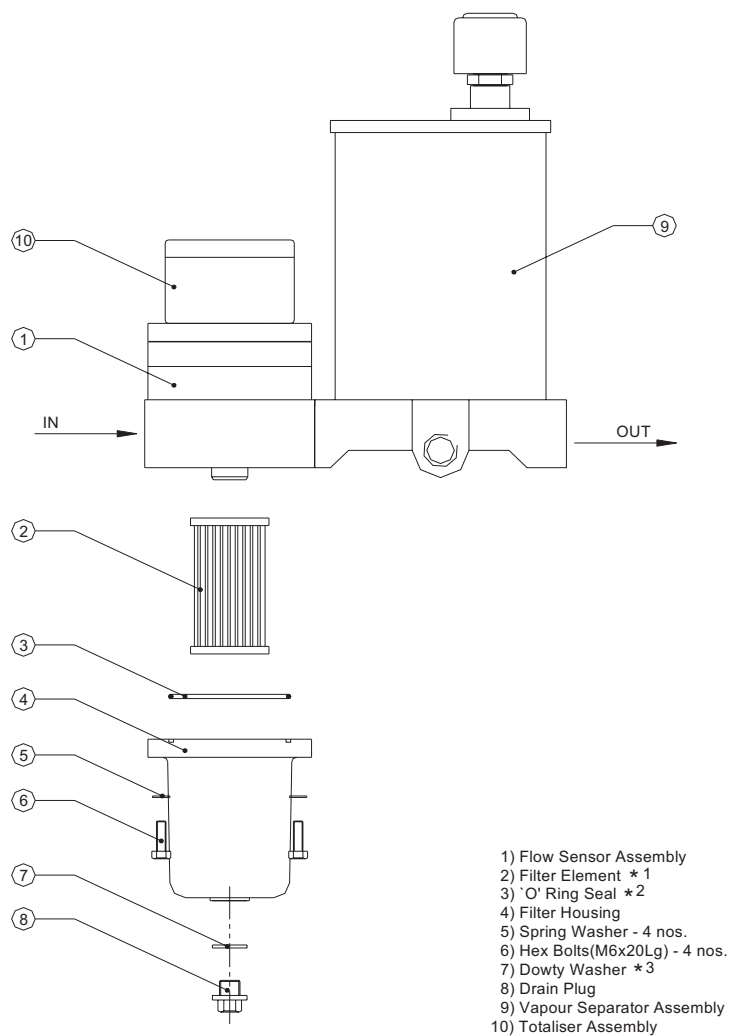

\* Denote Recommended Spares

# Section 8.

## Replacing The Float Assly

**Refer Air Seperator Assembly Schematic.**

- Remove 04 Allen Cap Screws M6 X 15 ( 2 ) along with 04 Nos. Dowty Washer ( 3 ).
- Firmly lift out Top Cover ( 4 )
- Lift out Housing ( 8 )
- Remove 04 Allen Cap Screws M4 X 10 ( 9 ) along with 04 Nos. spring washer ( 10 ).
- Lift Out Float assembly (11)
- Examine 03'O' Ring Seals (12) assembled on face of Manifold (14) Replace if found Damaged .
- Examine Ring Seal ( 7 ) assembled in groove on the face of Manifold .Replace if found Damaged.
- Correctly place new Float Valve Assembly taking care to ensure that 'O' Ring Seals ( 13 ) are assembled properly on the face of manifold ( 14 ).
- Firmly clamp Float Valve Assembly with 04 Allen Cap Screw M4 X 10(9) and ensure that spring washer ( 10 ) are assembled correctly.
- Place Housing ( 8 ) in the circular groove on Ring Seal ( 7 ) on face Of Manifold ( 14 )
- Examine Ring Seal ( 7 ) assembled in the groove on Top Cover ( 4 ). Replace if found damaged.
- Carefully position Top Cover ( 4 ) such that Adapter ( 5 ) aligns on Float assembly Air Outlet Port. Gently push the Top Cover so that Adapter ( 5 ) with its 'O' Ring on the outside diameter assembles into the Float Valve Air Outlet Port.
- Clamp Housing ( 8 ) with the help of 04 Cap Screws ( 2 ) and spring washer ( 3 ).
- Assembly is now ready for normal use.

\*Important : It is recommended to replace the Air Release Valve in the Float Assembly once a year to ensure leak proof performance of the Float Assembly.

## Air Separator Assembly Schematic Drawing

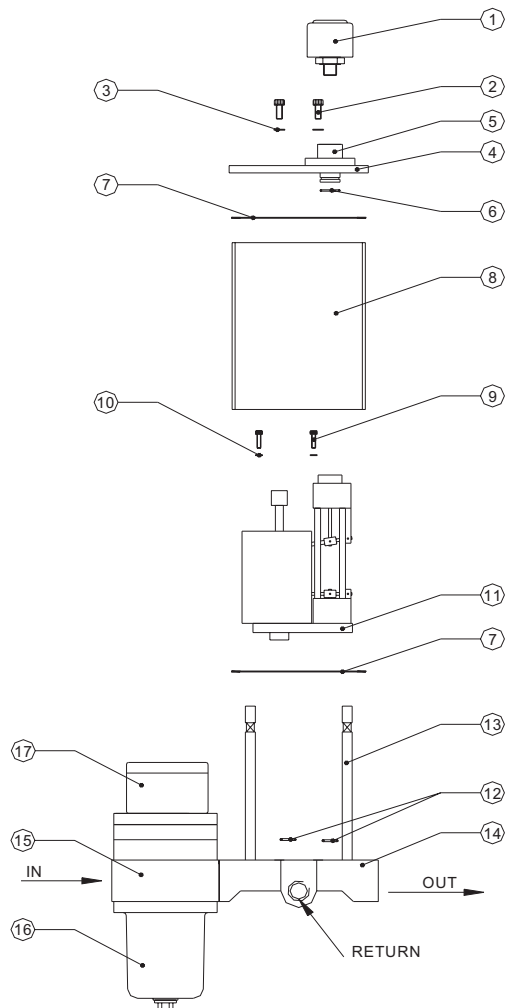

- 1) Breather
- 2) Allen Cap Screw(M6x15Lg) - 4 nos.
- 3) Dowty Washer - 4 nos.\*4
- 4) Top Cover
- 5) Breather Adaptor
- 6) 'O' Ring Seal \*5
- 7) Ring Seal \*6
- 8) Housing
- 9) Allen Cap Screw(M4x10Lg) - 4 nos.
- 10) Spring Washer - 4 nos.
- 11) Float Assembly \*7
- 12) 'O' Ring Seal - 3 nos.\*8
- 13) Clamp Stud - 4 nos.
- 14) Manifold
- 15) Flow Sensor Assembly
- 16) Filter Assembly
- 17) Totaliser Unit

\* Denote Recommended Spares

# Section 9.

## Cleaning The Flow Sensor Assembly

### Refer Flow Sensor Assembly Schematic.

In the event of dirt particles entering the FlowSensor Assembly owing to a incorrect or damaged filter, the assembly has to be opened and thoroughly cleaned with a solvent such as kerosene or diesel fuel. In the interest of through cleaning and proper re-assembly strictly follow the procedure given below.

- Refer FlowSensor Assembly Schematic
- Remove 02 Allen Cap Screw M6 X 15 ( 1 ) and 02 Spring Washer ( 2 ) lift out the Totaliser Assembly (3)
- Remove 04 Allen Cap Screw M6 X 40 ( 4 ) and 04 spring Washer ( 5 ) which clamp the entire FlowSensor module.
- Lift out 'O' Ring seal ( 6 ) assembled on the face of Top Cover ( 7 ) and the Top Cover.
- Lift our Piston ( 9 )
- Lift out body ( 11 ) along with partition ( 8 ). Remove 02 'O' Rings seals ( 10 ) from the face of body.
- Thoroughly clean the Top Cover, Partition, Piston, Body and Manifold face with the help of solvent like kerosene or diesel fuel. Remove all adherent dirt particles smooth out any burr with a fine emery stick or 600 grit emery paper. If emery paper or stick is used to deburr thoroughly washed all parts again in the solvent.
- Carefully examine the Piston ( 9 ) preferably under a magnifying glass. Carefully remove any metallic particles embedded on the bottom or top face and the outer diameter of the piston. Embedded metallic particles on the Piston are the single biggest reason for the piston jamming while in regular use. Thoroughly clean the piston with the solvent.
- Examine 02 'O' Rings ( 10 ) assembled in the Body ( 11 ). Replace if found damaged.
- Assemble 'O' Rings ( 10 ) on the both faces of the Body and locate and assemble the Body on the Manifold ( 12 ).
- Align the groove on the ID of the Body with the groove on the face of the Manifold and insert the Partition ( 8 ) such that it fully meshes with the groove in the Body and the Manifold. Ensure that the Partition has been fully located in the groove and its top faces with the circular cup of the Manifold.
- Aligning the profile on the Piston ( 9 ) with the Partition, assemble the piston inside the body. Gently rotate the piston inside the body. It should rotate freely without the slightest friction. If the Piston is found to stick at some point during its rotation or resist movement even slightly, repeat the cleaning procedure of all parts again. The free rotation of the Piston inside the body is the single most important condition for ensuring accuracy and proper functioning of the Flowmeter.



- Aligning the groove on the lowest face of the Top Cover ( 7 ) with the partition locate and assemble the Top Cover on the Body.
- Firmly clamp the Top Cover with the help of 04 Allen t friction or resistance to movement.
- Assemble the Totaliser Assembly on the Top Cover and firmly clamps with 02 Allen Cap Screws M6 X 15 ( 1 ) and 03 Spring Washer ( 2 )
- Keeping the Outlet Port of the Vapour Seperator Assembly ( 14 ) open blow air into the inlet. The free rotation of the piston should be felt and the totaliser should record the rotation.Cap Screws M6 X 40 ( 4 ) with spring washer ( 5 ).
- Examine 'O' Rings seal ( 6 ) on the face of Top Cover. Replace if found damaged.
- Gently try to rotate the Piston by rotating its pin guided in the hole on the Top Cover,. The piston should rotate freely without the slightes
- The assembly is now ready for use.

## Flow Sensor Assembly Schematic Drawing

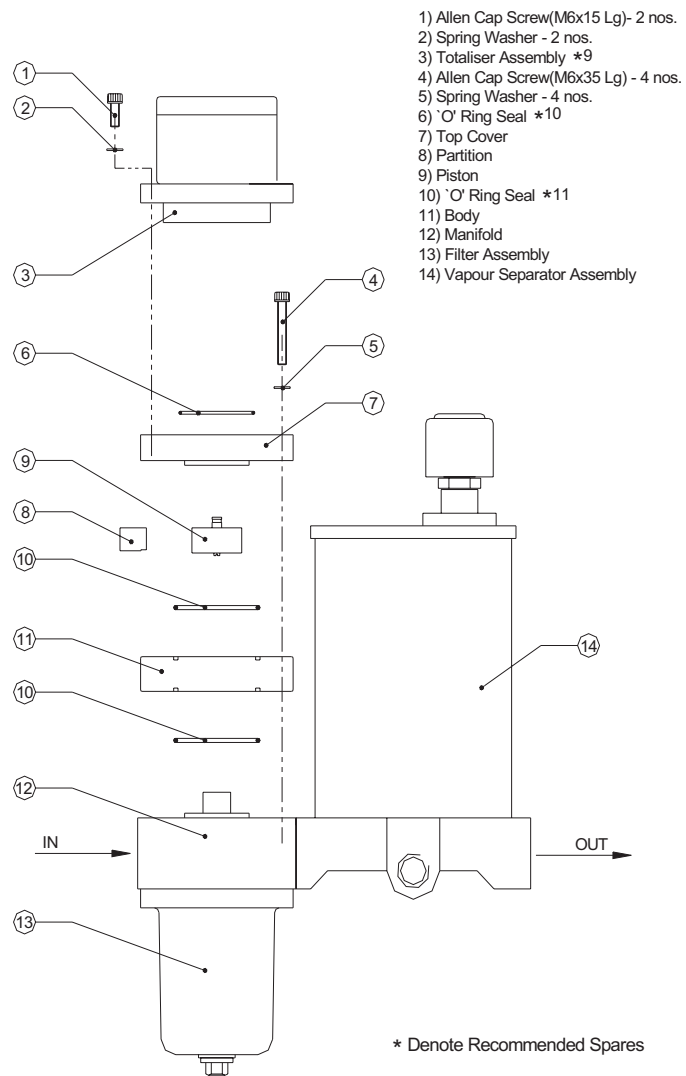

# Section 10.

## Servicing The Check Valve Assembly

### Refer Check Valve Assembly Schematic.

- Remove 02 cap screws M10 X 110 ( 5 ) with 02 spring washer ( 6 ).Detach Flow Sensor Assembly (10) From Air Seperator Assembly ( 8 ).
- Pull out Check Valve (1) and Spring (3) housed in the Flow Sensor Manifold (7).
- Clean the Check Valve housing in the Flow Sensor Manifold of any dirt or deposition.
- Clean the Check Valve and carefully clean any dirt or deposition sticking to its four guide ribs.
- Examine the Seal Ring ( 2 ). Replace if found damaged.
- Examine `O` Ring Seal ( 4 ). Replace if found damaged.
- Assemble the Check Valve and Spring in the Flow Sensor Manifold Housing. Ensure free back and forth movement of the Check Valve.
- Ensure `O` Ring seal ( 4 ) correctly assembled in its groove on the face of the Air Seperator Assembly Manifold ( 8 ) . Join the Flow Sensor Manifold and the Air Seperator Manifold together.
- Secure both assemblies by tightening 02 cap screws ( 5 ) with spring washer ( 6 ).
- The assembly is now ready for use.

## Check Valve Assembly Schematic Drawing

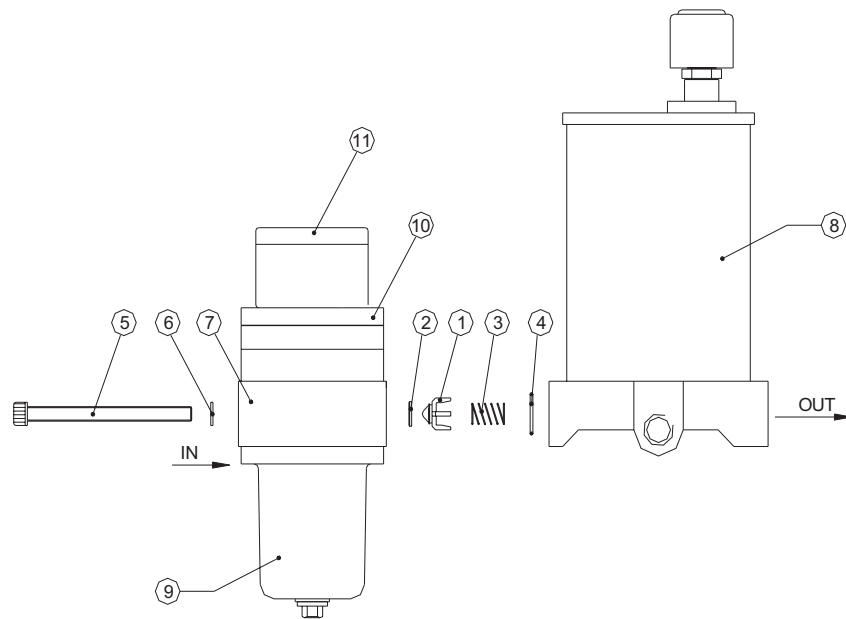

- 1) Check Valve
- 2) Seal Ring \* 12
- 3) Spring
- 4) O Ring Seal \* 13
- 5) Allen Cap Screw(M10X110Lg)- 2 nos.
- 6) Spring Washer - 2 nos.
- 7) Flow Sensor Manifold
- 8) Vapour Separator Assembly
- 9) Filter Assembly
- 10) Flow Sensor Assembly
- 11) Totaliser Assembly

\* Denote Recommended Spares

# Section 11.

## Replacing The Totaliser Lithium battery

### Refer Totaliser Assembly Schematic.

The Internal Lithium Battery is rated for 5 years continuous life. It is recommended to be changed every 4 years. In case the display on the Totaliser blanks out it is the sign of the end of the battery life. To change the battery proceed as follows.

- Loosen 04 Philips Head Screws (10). These are captive screws and as such are not required to be removed completely.
- Pull out front cover ( 9 ).
- Remove 04 CH Head Screws M3 X 10 (11).
- Using two flat head screw drivers wedged in the gap between edge of PCB1 ( 8 ) and the Housing( 1 ) pull out PCB1 ( 8 ). Disconnect 04 Male connector ( 7 ) on PCB1 from 04 Female Connector ( 3 ) on PCB2 ( 2 ).
- On the rear side of the PCB1 is assembled the Battery PCB ( 5 ).
- Remove 02 CH Head Screws M3 X 10 ( 4 ).
- Pull out Battery PCB ( 5 ) by disconnecting Male Connector ( 6 ) on Battery PCB ( 5 ) from corresponding Female Connector on rear face of PCB1.
- Assemble new Battery PCB ( 5 ) by carefully aligning all four Male Connector ( 6 ) on all four Female Connectors ( 4 ). Care should be taken to align the +ve terminal marking on the Battery PCB with +ve terminal marking on PCB1 to match the battery polarity.
- Secure the Battery PCB ( 5 ) by firmly tightening 02 nos . M3 X 10 CH Head Screws ( 4 ).
- Assemble PCB1 ( 8 ) on PCB2 ( 2 ) by carefully aligning all four Male Connector ( 7 ) on all four Female Connector ( 3 ). Firmly push in PCB1.
- Secure PCB1 by firmly tightening 02 CH Head Screw M3 X 10 (11).
- Assemble Front Cover ( 9 ) with Housing ( 1 ) by firmly tightening 04 Philips Head Screws ( 10 ).
- Press Reset Switch once to zeroise both totalisers. The 'O' display on both displays should be clearly visible.
- Unit is now ready for use.

## Totaliser Assembly Schematic Drawing

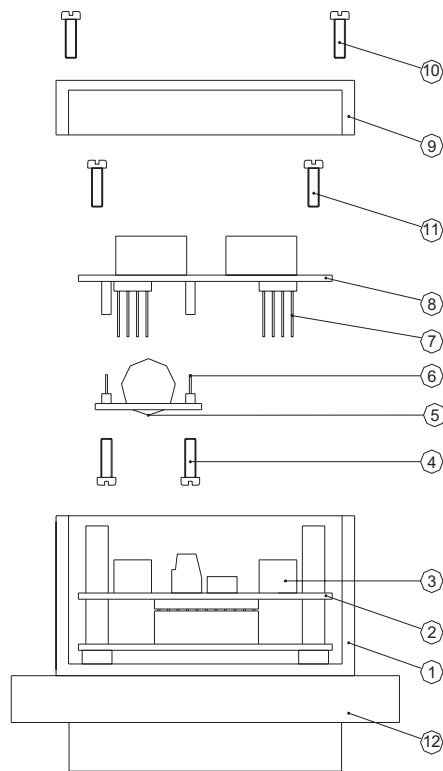

- 1) Housing
  - 2) PCB 2
  - 3) Female Connector
  - 4) Chease Head Screw(M3X10Lg)-2nos.
  - 5) Battery PCB \*14
  - 6) Male Connector
  - 7) PCB 1
  - 8) Male Connector
  - 9) Front Cover
  - 10) Philips Head Screw(M4x25Lg) - 4 nos.
  - 11) Chease Head Screw(M3x10Lg) - 4 nos.
  - 12) Totaliser Assembly
- \* Denote Recommended Spares

# Section 12.

## List of Recommended Spares

Ident. No.	Part No.	Description	Qty. Required Per Assembly
*1	29004	Filter Element - 25 microns	1
*2	07025	`O' Ring Seal - 72.4 x 2.62	1
*3	07100	Dowty Washer - ¼"	1
*4	07102	Dowty Washer - M6	4
*5	07023	`O' Ring Seal - 17.0 x 1.5	1
*6	07026	Ring Seal – 186.0 x 174.0 x 1.0	2
*7	23001	Float Assembly	1
*8	07019	`O' Ring Seal - 12.0 x 2.0	3
*9	23002	Totaliser Assembly	1
*10	07004	`O' Ring Seal - 47.7 x 1.78	1
*11	07014	`O' Ring Seal - 53.5 x 2.62	2
*12	07027	Seal Ring - 17.0 x 12.0 x 2.0	1
*13	07028	`O' Ring Seal - 25.0 x 2.0	1
*14	16014	Battery PCB	1

# Section 13.

## Frequently Asked Questions (FAQs)

**Q1.** Can I use a Flowmeter to measure the fuel consumption of a Genset?

**A1.** Any Genset of whatever capacity has return fuel coming back to the fuel storage tank. To measure the net fuel consumption of the engine return fuel accounting is essential. Hence a single flowmeter is not sufficient to measure the net fuel consumption of the engine.

**Q2.** Does my aim of measurement get solve by using one flowmeter each in the supply and return line and calculating the summation of their through put?

**A2.** Theoretically the answer to the question is yes. however the return fuel flowrate in small genset is very low more over the return fuel is hot and laden with air and vapor which makes volumetric measurement with a flowmeter in the return line impossible. Hence use of two flow meter is not a particle solution for genset fuel measurement.

**Q3.** What is then a proven method to measure net Genset consumption?

**A3.** Cummins 'Monitor Fuel Consumption' Part No.AX1006412 is time tested proven method to measure net consumption of gensets. It uses a single flowmeter and return line fuel conditioning to meet the exact need of the application.

**Q4.** What Information do I get from the Monitor Fuel Consumption?

**A4.** The Monitor Fuel Consumption basically measures and displays the totalised the net fuel consumption in Litres and the Run Hours.

**Q5.** Does the Monitor Fuel Consumption directly save fuel for me?

**A5.** The Monitor Fuel Consumption provides accurate fuel measurement which is the first step to conserving fuel. Knowing the accurate fuel consumption method can be devised to improve engine efficiency, control fuel pilferage, eliminate fuel wastage which all lead to save fuel. The saving can once again be confirmed through the Monitor Fuel Consumption.

**Q6.** Will I Require an infallible power supply for the Monitor Fuel Consumption?

**A6.** The Monitor Fuel Consumption is self powered and hence can perform during power failures as well.

**Q7.** Does the Monitor Fuel Consumption require any routine maintenance which is unsuitable for continuous running gensets.

**A7.** The monitor Fuel Consumption is so designed and installed that it can be used for continuous use without having to bother about any kind of maintenance.

**Q8.** Can I use the Monitor Fuel Consumption as a test instrument to measure periodic consumption of a range of sets I have in my Power House?

**A8.** Yes, The Monitor Fuel Consumption can be very quickly and easily disconnected from one engine and connect to another set if required. It can also be supplied in a portable kit from to facilitate easy transportation.

**Q9.** Is the Monitor Fuel Consumption available in different model to suit different capacity engine?

**A9.** One Single model of the Monitor Fuel Consumption is suitable to measure engines from 50KVA to 1500KVA gensets.

**Q10.** Do I have to provide a set minimum fuel gravity head for the operation of the Monitor Fuel Consumption?

**A10.** The unit doesn't require gravity head for its operation. In fact it can work equally well under negative head condition.

# Section 14.

## Fuel & Hour measurement calibration

- The unit is supplied with a calibration certificate after wet testing the product . The certification is valid for one year.
- It is recommended to recalibrate the unit once every year.
- CDSS provided on site calibration service to avoid measurement down time and the trouble of sending the unit back to Pune for calibration.
- Onsite calibration is done by a qualified engineer with the help of a
  - a) Master Flowmeter for measurement of fuel.
  - b) Calibration Stop Watch for measurement of engine run Hour.The instrument used for calibration are traceable to national standards and copy of their trace ability certificate will be attached to the calibration certificate of the unit.
- After calibration a proper calibration certificate will be issued on the site with relevant traceability documents.
- The genset will have to be spared for minimum 8 hour for completing the calibration procedure.

# Section 15.

## Do's & Don'ts for Installation & Use

### Do's

1. The unit should be mounted on the ground next to the engine base frame and should be grouted with the help of fasteners provided.
2. The unit should be installed between the engine fuel filter and the fuel pump.
3. Use of rubber hoses of recommended is preferable to rigid metal pipes for easy connection of the unit.
4. Use recommended oil pressure switch to activate the engine run hours totaliser of the unit.
5. The recommended calibration interval of the unit is one year.
6. The unit should be used on fuels like HSD, Kerosene and LDO

### Dont's

1. Never mount the unit on the engine base rail or any vibrating structure.
2. Do not mount the engine before the engine fuel filter.
3. The unit is self-powered. Do not try to connect any kind of a power supply to the unit.
4. Do not use NPT end fittings for hose connection. Use only recommended Cummins end fittings.
5. Do not share the contacts of an already installed Oil Pressure Switch on the engine. Use of independent pressure switch is highly recommended.
6. The unit is not suited for use on heated fuel like FO & HFO.



Test Certificate

To:

Date of Test:  
Serial No.:

System Under Test : Fuel Consumption Monitor (AX10064\_ \_)

Flow Range : 6-500 LPH

Liquid Used for Calibration : Diesel

Liquid Specific Gravity :  
(At operating ambient temp.,  
calculated using Archimedes principle)

Equivalent Weight of 10 ltr volume :

Scale Factor for Totaliser :

Accuracy : +/- 0.5% of Reading

Test Equipment Used : Electronic Weighing Scale  
1. Capacity : 10.0 Kg  
2. Least Count : 0.001 Kg  
3. Traceability : Certified by W&M Dept.

**Test Report**

Flow Rate LPH	Batch Weight Kg.	Equivalent Batch Volume Ltrs.	Meter Reading Ltrs.	% Accuracy
6				
30				
60				
120				
240				
360				
500				

.....  
**Tested By:**  
.....



Customer Copy

**FCM Details**

Part No.: .....  
Serial No.: .....  
Date of Installation:.....

**Genset Details**

Model:..... ESN No.:.....  
Month & Year of Installation:.....

CSS guarantees all manufactured equipment to be free from defects in materials and workmanship for a period of 12 months from the date of commissioning or 15 months from the date of delivery whichever is earlier to the original buyer, if properly used in accordance with our Operating Instructions. The liabilities under this guarantee is limited to replacement parts and labour on equipment when with prior authorization from us it is returned prepaid to the factory and when, upon examination by us is determined to be defective. All costs incurred in despatching the equipment or parts thereof to and fro are the responsibility of the buyer. Our guarantee of this equipment is rendered void if the unit has been repaired, taken apart or modified, or attempted to be, unless such actions have been taken in accordance with written instructions received from us. The guarantee will also not cover any other financial loss or otherwise due to non-functioning or absence of the equipment. The equipment must be checked on receipt. If any packing or surface defects are observed on receiving or at a later date prior to installation, the Insurer and we should be suitably informed in writing. If the buyer does not comply with the above, we will consider ourselves free from the obligations of this guarantee.

All disputes relating to this equipment will be subject to Pune Jurisdiction.

**IN THE EVENT OF TRANSIT DAMAGE PROCEED AS FOLLOWS**

- 1) Notify us, giving full details of the difficulty, and include the model number and serial number of the equipment. On receipt of this information, service data or despatch instructions will be given. Do not return the unit for repairs without contacting our factory or our Sales Representative.
- 2) On receipt of despatch instructions, forward the equipment prepaid to our factory. An estimate of the repair charges will be made before the work begins, in cases where the equipment is not covered by the guarantee.
- 3) If the original carton and packing are not available, the equipment should be packed in a strong container and surrounded by 5 to 7 cms of shock-absorbing material. We advice that returned equipment should be declared at full value to the carrier, freight and insurance prepaid.

We reserve the right to make changes in design at any given time without incurring any obligation to install the same on units previously purchased.

**Signature & Stamp of Dealer with Address & Tel. No.**

**Cummins Sales and Service (I) Ltd.**  
35A/1/2, Erandawana, Pune 411038  
Phone +91 020 2543 1234, 2543 0066  
Fax +91 020 2543 9490  
Toll Free 1 800 2332000  
Email powermaster-india@cummins.com  
Internet www.cumminsindia.com



Dealer Copy

**FCM Details**

Part No.: .....  
Serial No.: .....  
Date of Installation:.....

**Customer Information**

Name:.....  
Address:.....  
City:..... Pin Code:.....  
State:..... Tel. No.:.....  
Email:.....  
Contact Person:..... Designation:.....  
Signature :..... Contact No.....

**Genset Details**

Model:..... ESN No.:.....  
Month & Year of Installation:.....

CSS guarantees all manufactured equipment to be free from defects in materials and workmanship for a period of 12 months from the date of commissioning or 15 months from the date of delivery whichever is earlier to the original buyer, if properly used in accordance with our Operating Instructions. The liabilities under this guarantee is limited to replacement parts and labour on equipment when with prior authorization from us it is returned prepaid to the factory and when, upon examination by us is determined to be defective. All costs incurred in despatching the equipment or parts thereof to and fro are the responsibility of the buyer. Our guarantee of this equipment is rendered void if the unit has been repaired, taken apart or modified, or attempted to be, unless such actions have been taken in accordance with written instructions received from us. The guarantee will also not cover any other financial loss or otherwise due to non-functioning or absence of the equipment. The equipment must be checked on receipt. If any packing or surface defects are observed on receiving or at a later date prior to installation, the Insurer and we should be suitably informed in writing. If the buyer does not comply with the above, we will consider ourselves free from the obligations of this guarantee.

All disputes relating to this equipment will be subject to Pune Jurisdiction.

**IN THE EVENT OF TRANSIT DAMAGE PROCEED AS FOLLOWS**

- 1) Notify us, giving full details of the difficulty, and include the model number and serial number of the equipment. On receipt of this information, service data or despatch instructions will be given. Do not return the unit for repairs without contacting our factory or our Sales Representative.
- 2) On receipt of despatch instructions, forward the equipment prepaid to our factory. An estimate of the repair charges will be made before the work begins, in cases where the equipment is not covered by the guarantee.
- 3) If the original carton and packing are not available, the equipment should be packed in a strong container and surrounded by 5 to 7 cms of shock-absorbing material. We advice that returned equipment should be declared at full value to the carrier, freight and insurance prepaid.

We reserve the right to make changes in design at any given time without incurring any obligation to install the same on units previously purchased.

**Cummins Sales and Service (I) Ltd.**

35A/1/2, Erandawana, Pune 411038  
Phone +91 020 2543 1234, 2543 0066  
Fax +91 020 2543 9490  
Toll Free 1 800 2332000  
Email powermaster-india@cummins.com  
Internet www.cumminsindia.com



CSS Copy

(To be submitted to CSS for registration of warranty)

**FCM Details**

Part No.: .....  
Serial No.: .....  
Date of Installation:.....

**Customer Information**

Name:.....  
Address:.....  
City:..... Pin Code:.....  
State:..... Tel. No.:.....  
Email:.....  
Contact Person:..... Designation:.....  
Signature :..... Contact No.....

**Genset Details**

Model:..... ESN No.:.....  
Month & Year of Installation:.....

CSS guarantees all manufactured equipment to be free from defects in materials and workmanship for a period of 12 months from the date of commissioning or 15 months from the date of delivery whichever is earlier to the original buyer, if properly used in accordance with our Operating Instructions. The liabilities under this guarantee is limited to replacement parts and labour on equipment when with prior authorization from us it is returned prepaid to the factory and when, upon examination by us is determined to be defective. All costs incurred in despatching the equipment or parts thereof to and fro are the responsibility of the buyer. Our guarantee of this equipment is rendered void if the unit has been repaired, taken apart or modified, or attempted to be, unless such actions have been taken in accordance with written instructions received from us. The guarantee will also not cover any other financial loss or otherwise due to non-functioning or absence of the equipment. The equipment must be checked on receipt. If any packing or surface defects are observed on receiving or at a later date prior to installation, the Insurer and we should be suitably informed in writing. If the buyer does not comply with the above, we will consider ourselves free from the obligations of this guarantee.

All disputes relating to this equipment will be subject to Pune Jurisdiction.

**IN THE EVENT OF TRANSIT DAMAGE PROCEED AS FOLLOWS**

- 1) Notify us, giving full details of the difficulty, and include the model number and serial number of the equipment. On receipt of this information, service data or despatch instructions will be given. Do not return the unit for repairs without contacting our factory or our Sales Representative.
- 2) On receipt of despatch instructions, forward the equipment prepaid to our factory. An estimate of the repair charges will be made before the work begins, in cases where the equipment is not covered by the guarantee.
- 3) If the original carton and packing are not available, the equipment should be packed in a strong container and surrounded by 5 to 7 cms of shock-absorbing material. We advice that returned equipment should be declared at full value to the carrier, freight and insurance prepaid.

We reserve the right to make changes in design at any given time without incurring any obligation to install the same on units previously purchased.

**Signature & Stamp of Dealer with Address & Tel. No.**

**Cummins Sales and Service (I) Ltd.**  
35A/1/2, Erandawana, Pune 411038  
Phone +91 020 2543 1234, 2543 0066  
Fax +91 020 2543 9490  
Toll Free 1 800 2332000  
Email powermaster-india@cummins.com  
Internet www.cumminsindia.com

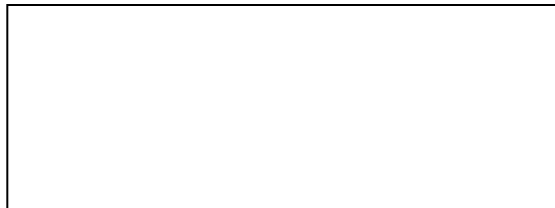

**Cummins Sales and Service (India) Ltd.**  
**35 A/1/2, Erandwana, Pune 411 038**

Phone +91-20-2543 0066, 2543 1234

Fax +91-20-2543 9490

Toll Free 1-800-2332000

Internet: [www.CumminsIndia.com](http://www.CumminsIndia.com)